

PRESSUREAIDE®

COVERED HOPPER CAR



“The Single Source for all your Railcar Needs.” SM

The ARI Pressureaide® covered hopper is available in three models, 3300, 5300, and 5750 cubic feet capacity, which optimize gross rail loads for a variety of products. It is specifically designed and engineered to handle a wide variety of dry bulk fluidizeable products in a safe and efficient manner. The Pressureaide® car operates with internal pressures up to 14.5 psig, which allows for faster unloading. Safety is a priority with ARI, each car is equipped with several safety relief devices such as pressure relief valves, a rupture disc and a vacuum relief valve.



PRESSUREAIDE® 3300

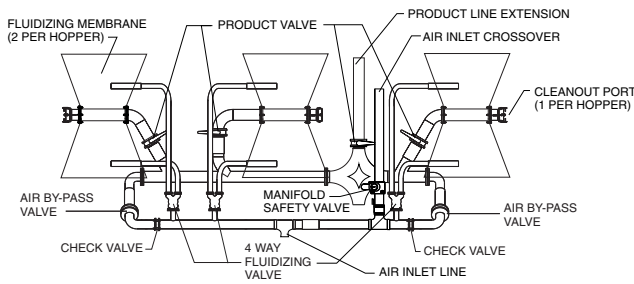
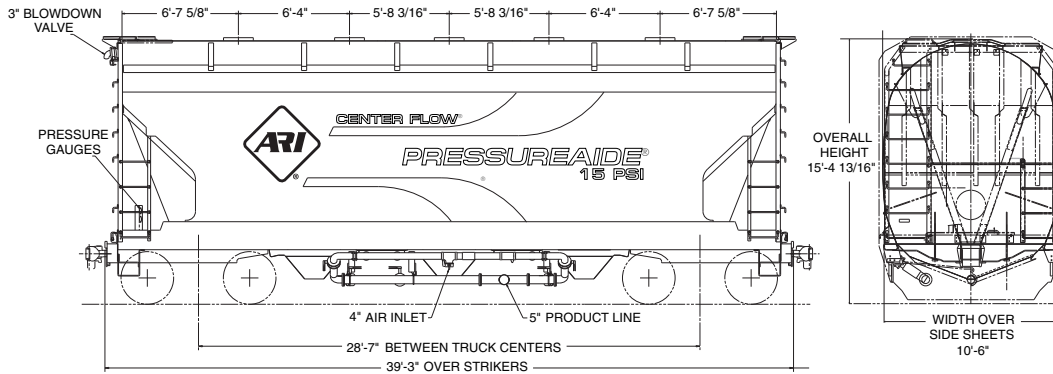

**CF3300
MANIFOLD
ARRANGEMENT**

PRESSUREAIDE® 5300

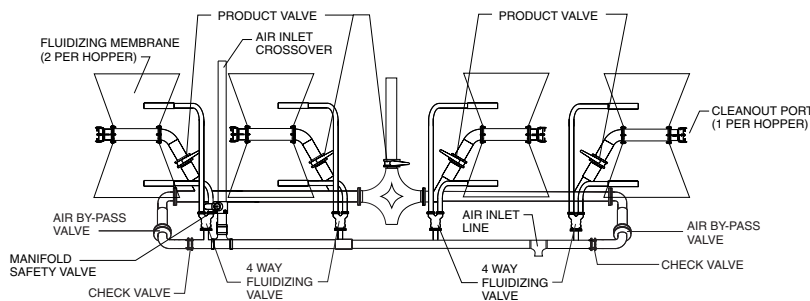
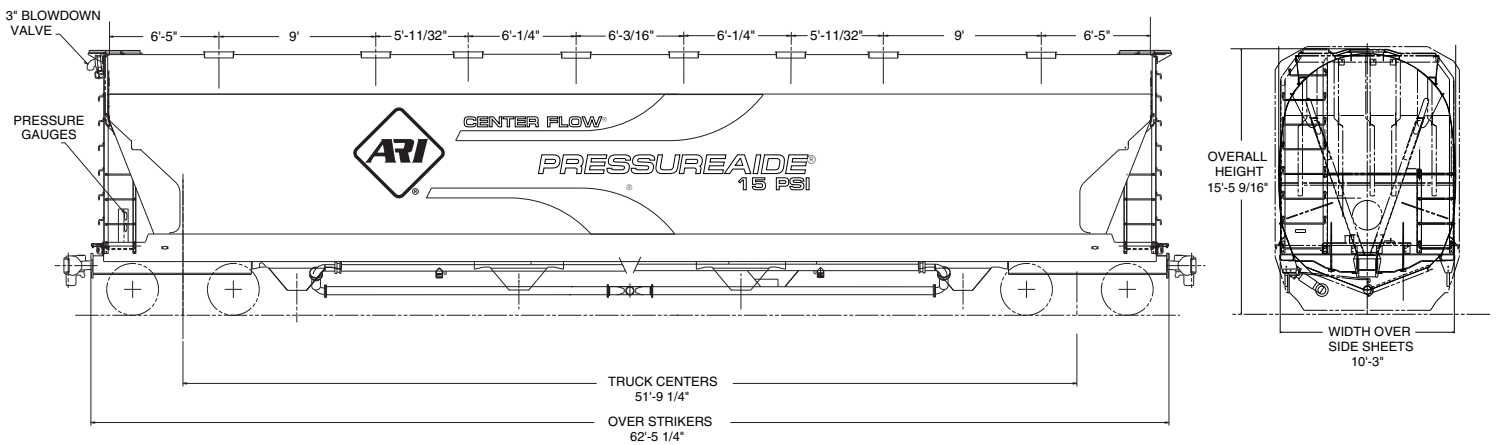

**CF5300
MANIFOLD
ARRANGEMENT**

PRESSUREAIDE® 5750

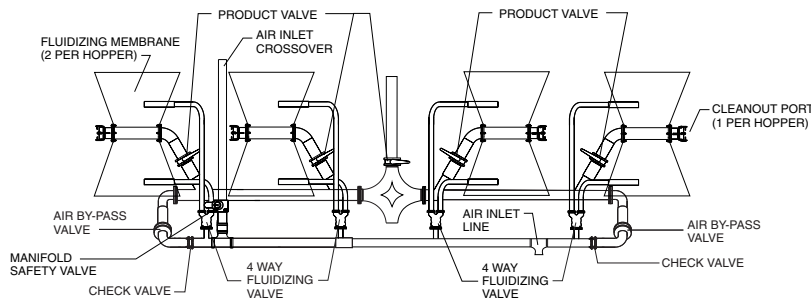
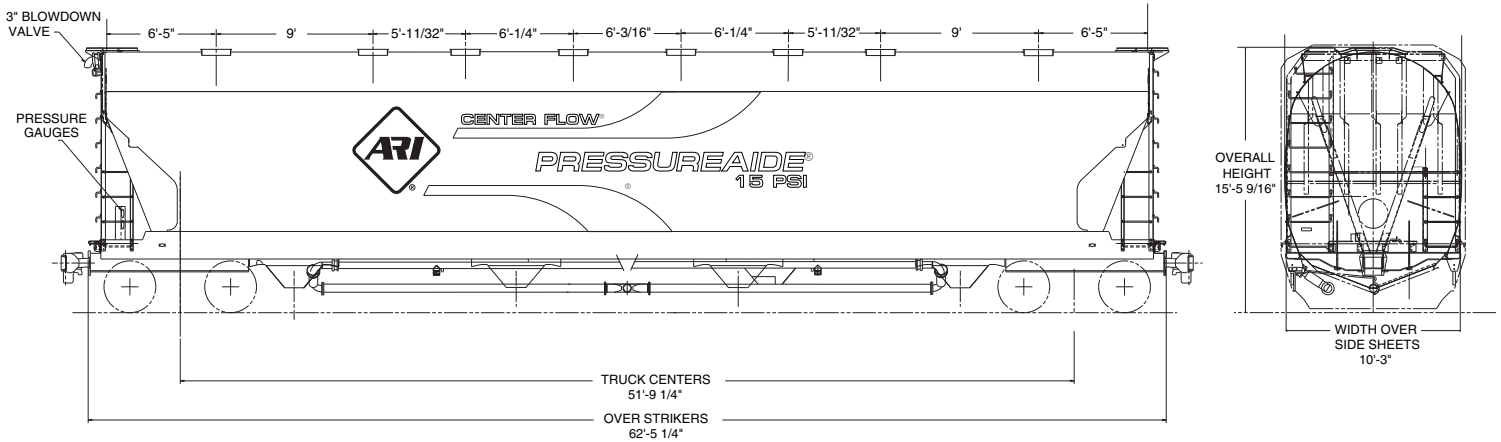

**CF5750
MANIFOLD
ARRANGEMENT**

BASIC SPECIFICATIONS

3300

5300

5750

LENGTH OVER PULLING FACE	41'- 10 1/2"	65'- 3/4"	65'- 3/4"
TRUCK CENTERS	28'- 7"	51'- 9 1/4"	51'- 9 1/4"
OVERALL HEIGHT	15'- 4 13/16"	15'- 5 9/16"	15'- 5 9/16"
WIDTH OVER SIDE SHEETS	10' 6"	10' 3"	10' 3"
HEIGHT RAIL TO BOTTOM OF DISCHARGE OUTLETS	13"	13"	13"
NUMBER OF COMPARTMENTS	3	4	4
NUMBER OF OUTLETS PER HOPPER	1	1	1
SIZE OF ROOF HATCHES	20" DIA.	20" DIA.	20" DIA.
SLOPE END FLOOR SHEET	50°-43°	50°-43°	43°-45°
SLOPE INTERIOR FLOOR SHEET	50°	50°-45°	43°-45°
SLOPE SIDE SLOPE SHEET	45°	45°	51°
CUBIC CAPACITY	3300 CU.FT.	5300 CU.FT.	5750 CU.FT.
ESTIMATED NOMINAL LIGHTWEIGHT	57,400 LBS.	71,500 LBS.	71,500 LBS.
HORIZONTAL CURVE NEGOTIABILITY – UNCOUPLED	150 FT.	180 FT.	180 FT.

NOTE: All ARI Pressureaide® covered hopper cars are built to 286,000 lb. GRL specifications.
All dimensions are for nominal light car.

OPERATING INSTRUCTIONS

1 Prior to Hook-up Inspect to Ensure That:

- a. All hatch covers are secure.
- b. There is no pressure on the car body or the manifold by venting the car body through the blowdown valve and opening one fluidizing valve and one product valve.
- c. Inspect pressure gages to insure they are intact and read "0" psig.

2 Hook-Up

- a. Remove dust cap on product line and connect product conveying line.
- b. Remove dust cap from air inlet line and connect air supply line.
- c. Close all valves including the blowdown valve.

3 Pressurization

- a. Open fluidizing air valve on first compartment to be unloaded (start from one end of car).
- b. Start blower and pressurize car to 14.0 to 14.5 psig. Monitor car pressure using car body pressure gage. (NOTE: pressure may be limited by air supply system)

4 Unloading a Compartment (when pressure is reached)

- a. Open the by-pass air valve on end of car being unloaded to full open position.
- b. Open the product valve to start unloading.
- c. Adjust both valves to achieve best product flow and best air/product mixture. Long conveying lines generally require more by-pass air to assist conveying while less by-pass air is

required for short conveying distances. In general, optimum unloading rates are achieved when the manifold pressure gage reading is 1-3 psig higher than the car body pressure gage reading.

- d. A rapid drop in car body pressure indicates that the compartment is empty. Close the by-pass and product valves while continuing to supply air. Open and close the product valve on about twenty-second intervals four or five times for final cleanout. Use by-pass air as needed.
- e. Close product and by-pass valves.
- f. Open fluidizing air valve on next compartment and close fluidizing air valve on compartment just finished.
- g. Allow car body pressure to rebuild to 14.0 to 14.5 psig.
- h. Repeat steps "a" through "g".
- i. When final compartment is unloaded, open both by-pass air valves; close all product valves and fluidizing air valves, blow conveying lines clean. Turn off blower.
- j. Depressurize the car body and manifold by venting the car body through the blowdown valve and opening one fluidizing valve and one product valve.

Disconnect hookups when pressures have been reduced to zero. Close blowdown valve and secure product line and air inlet dust caps prior to shipping.

CAUTION

Car pressure must be zero before car is shipped.



AMERICAN RAILCAR INDUSTRIES

100 Clark Street, St. Charles, Missouri 63301

(636) 940-6020 • FAX: (636) 940-6100

e-mail: sales@americanrailcar.com / website: www.americanrailcar.com

THE SINGLE SOURCE FOR ALL YOUR RAILCAR NEEDSSM